

FINAL REPORT ON ACCIDENT TO FAST HELICHARTERS INDIA PVT. LTD.
HELICOPTER BELL 206 B III VT-TBA AT GODHRA (GUJARAT) ON
29/08/2012

1. Helicopter
Type : BELL 206 B III
Nationality : INDIAN
Registration : VT - TBA
2. Owner/ Operator : FAST HELICHARTERS INDIA PVT. LTD.
3. Pilot – in –Command : Holder of CPL(H)
Extent of injuries : Nil
4. Co-Pilot : NIL
Extent of injuries : N/A
5. Place of Accident : GODHRA (GUJARAT)
6. Coordinates of Accident Site : 22-46-94 (N),
073-37-652 (E)
7. Last point of Departure : MORBI (GUJARAT)
8. Intended place of Landing : GODHRA (GUJARAT)
9. Date & Time of Accident : 29 Aug 2012
0430 UTC (Approx.)
10. Passengers on Board : 4
Extent of Injuries : NIL
11. Phase of Operation : Landing
12. Type of Accident : During Landing the Helicopter
Topped Over

(ALL TIMINGS IN THE REPORT ARE IN UTC)

SUMMARY

On 29/08/2012 M/s Fast Helicharters India Pvt. Ltd. Helicopter Bell 206 B III VT-TBA (Sl. No. 4224) was operating a charter flight from Morbi to Godhra (Gujarat). Previous to the day of accident, the helicopter did a night stop at Morbi. The AME had refueled the helicopter as per the advice of the PIC and the programme. The following day, the helicopter was released by the AME for flight at around 0130 UTC. The helicopter was fully serviceable as no defect was reported by the PIC on the previous sector.

At around 0230 UTC the PIC repositioned the helicopter for the passengers boarding. 04 passengers were boarded on the helicopter with rotors running. Thereafter, the helicopter took off for Godhra at around 0245 UTC. The enroute flight was uneventful. The helicopter reached overhead the landing site, a cemented helipad in the middle of an open ground. Thereafter the PIC carried out an aerial reconnaissance and commenced descent for landing. At approx. 300 feet, after crossing the obstruction, the helicopter experienced a sink and lost height considerably. The PIC tried to control the helicopter, however in the process; the helicopter contacted the ground (37 meters away from helipad) on the rear portion of the right skid and subsequently, rolled over. There was no fire after the accident. All the 05 occupants on the helicopter escaped unhurt.

The Ministry of Civil Aviation constituted a committee of inquiry to investigate the cause of the accident under Aircraft (Investigation of Accidents and Incidents), Rules 2012 comprising of Sh. Yash Pall as Chairman and Sh. A X Joseph and Capt. JPS Kniggar as members.

1. FACTUAL INFORMATION

1.1 History of the flight.

The M/s Fast Helicharters helicopter Bell 206 B III, Reg. No. VT-TBA was chartered by Satsang Samiittee, Ahmadabad, for operations in Gujarat from 25/08/2012 to 29/08/2012. Prior to the accident flight, the helicopter did the entire operations uneventfully. The helicopter was flown by a single pilot. The Co-Pilot controls were removed to facilitate a passenger to occupy the front seat. Helicopter Bell 206 B III VT-TBA was operating the last leg of the charter, on 29/08/2012, and the flight was from Morbi to Godhra. During night halt, the helicopter was refueled, as per instructions of the PIC, in the evening by the AME / authorized person. The Pre-Flight Checks of the helicopter were carried out on the following morning, as per the scope of his authorization and the helicopter was released for flying. The helicopter was fully serviceable as no defect had been reported by the PIC on the previous sector. The Tech Log was completed in respect of Pre-Flight Checks and refueling /oil upliftment etc. The Load and Trim sheet was prepared by the PIC for 03 passengers on board, however, 04 passengers boarded the helicopter. Fresh / New Load & Trim Sheet was not prepared.

At around 0230 UTC the PIC repositioned the helicopter for the passengers boarding. Before the helicopter was switched off, the passengers boarded the helicopter with the rotors running. The passengers boarded the helicopter without any security check and passenger briefing. Though, the flight was planned with 03 passengers, actually 04 passengers boarded the helicopter. The PIC without recalculating the power requirements and change in Centre of Gravity position, took off from Morbi for Godhra at 0245 UTC.

During the 1Hr 45 minutes of flight, the PIC co-ordinated with the enroute Air Traffic Control Units (Rajkot & Vadodara) for obtaining the latest weather updates and continued the flight to Godhra. On reaching, the PIC made a large circle to identify the

landing site, assess the helipad (concrete) area, obstructions around the helipad, winds and decided upon the approach direction before commencing the descent.

After crossing the high-tension wires with sufficient clearance, the helicopter continued the approach. The PIC mentioned that he had observed the Main Rotor and engine indicator showing 97% rpm (within normal operational limit 97 to 100 %) He further stated that after crossing the wires, sink was experienced. To arrest the sink he came up on collective and noticed that the main rotor and engine rpm indicator decreased and stabilized between 97% and 90 %. Subsequently he lowered the collective to regain the rpm. The PIC assessing the situation to be as one of the governor failure (engine underspeed) decided to carry out landing with forward speed. He further mentioned that the approach was undershooting and that the helicopter would arrive short of the helipad, if he did not make any corrections/adjustments to the flight path. The PIC did not make any adjustments, to the forward speed and rate of descent of the helicopter, to cater for the undershoot. At approximately 25 feet above ground, the PIC applied collective in an attempt to reduce the rate of descent and forward speed. Seeing that the rate of descent was not decreasing at the expected/desire rate, he applied full collective and attempted to land with forward speed. The helicopter yawed and banked to the starboard (right) close to the ground and impacted the ground on the rear portion of the right skid with a right bank followed by the left skid digging into the ground and the helicopter toppling over. The Main Rotors cut the tail-boom of the helicopter and got dislodged from the mast. The Main Rotor Hub along with rotor flew away and was found at a distance.

All the 05 occupants on board the helicopter, escaped unhurt. There was no fire after the accident.

1.2 Injuries to persons.

INJURIES	CREW	PASSENGERS	OTHERS
FATAL	Nil	Nil	Nil
SERIOUS	Nil	Nil	Nil
MINOR/None	01	04	----

1.3 Damage to Helicopter.

The helicopter sustained substantial damage. Examination of the helicopter wreckage revealed no airframe pre-impact anomalies. All observed fractures were consistent with overload fractures occurring at impact.

Details of damages:

- a) The Main Rotor Blades had hit tail boom and both separated from the main structure.
- b) Main rotor blades were broken, fuselage was smashed, cockpit interior was generally broken, (instrument panel was intact, Central Warning Panel (CWP) and the various gauges were generally intact).
- c) The tail rotor head and the blades were attached to the TGB when the tailboom separated from the fuselage. The entire section was not available for inspection, as the same had been taken away by the by-standers, therefore the Vertical Fin, Tail Gear Box and Tail Drive Shaft were missing.
- d) The left passenger door and crew door were completely destroyed. The nose section including, pitot head, control pedestal, instrument panel etc after hitting the ground were damaged. The helicopter battery compartment and battery were damaged.
- e) After hitting the ground, the Main Rotor mast sheared off the main rotor hub along with blades and they were separated from the helicopter and were found some distance away. The associated main rotor pitch change links were broken, one of the main rotor blades was bent inward apparently due to impact, the hub was not damaged.

- f) After impacting with the ground the rear skid pierced the bottom surface and ruptured the main fuel tank.

1.4 Other damage: Nil

1.5 Personnel information:

1.5.1 Pilot – in – Command:

Name	:	Holder of DGCA Licence
AGE	:	45 years
Licence	:	CPL (H)
Date of Issue	:	05/05/2008
Valid up to	:	04/05/2013
Category	:	Helicopter
Class	:	Single Engine Land
Endorsements as PIC	:	Alouette III/Chetak, Bell 206 B3
Date of Med. Exam.	:	19/06/2012
Med. Exam valid upto	:	18/12/2012
FRTTO License No.	:	Valid
Date of issue	:	05/05/2008
Valid up to	:	04/05/2013
Total flying experience	:	2372:35 hrs
Last flown on type	:	27/08/2012
Total Hrs on type	:	226 hrs 15 mts
Total flying experience during last 180 Days	:	68:45 hrs
Total flying experience during last 90 Days	:	36:00 hrs
Total flying experience during last 30 Days	:	10:50 hrs
Total flying experience during last 07 Days	:	05:50 hrs
Total flying experience during last 24 Hours	:	NIL

Scrutiny of the PIC log book, shows no record of any Flight Duty Time Limitation violation. He was not involved in any Serious Incident/Accident in the past. At the time of accident he was not current on all ancillary trainings. The PIC had not undergone the simulator training as required by DGCA CAR Section 7, Series B Part XIV for helicopter pilots.

1.6 Aircraft information:

Construction:

HELICOPTER DESCRIPTION

Bell 206 B III is single pilot, five place, single engine, light helicopter with a two-blade semi rigid main rotor, and a tail rotor that provides directional control.

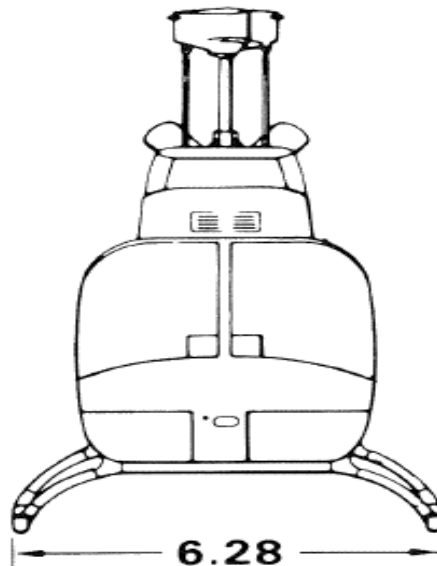

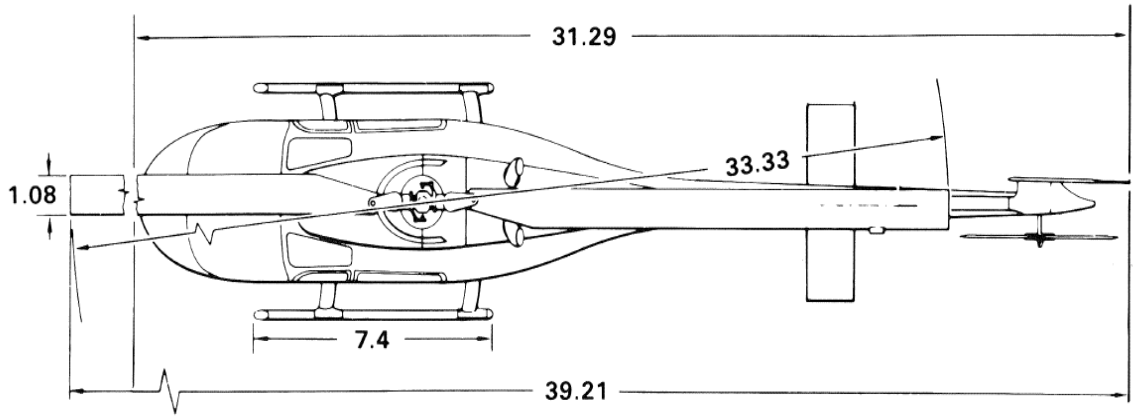

Dimensions in Feet

The airframe consists of a semimonocoque fuselage with metal and fiberglass covering; an aluminum-alloy monocoque tail-boom that supports the vertical fin, fixed horizontal stabilizer, tail rotor, and tail rotor drive train; and aerodynamically shaped couplings and fairings to protect all roof mounted components. The primary load-carrying structures are two built in cabin bulkheads, a vertical control tunnel from the floor to the cabin roof, and a pair of longitudinal beams in the cabin roof.

Landing gear is tubular skid type made of aluminum alloy. Optional pop-out or fixed floats are available.

POWER PLANT

Bell 206 B III is powered by a single Allison 250-C20J engine. Maximum output is 420 SHP (313 kW), but due to transmission limits, the engine is flat rated to 317 SHP (236 kw). The engine consists of a multistage axial-centrifugal-flow compressor, a single combustion chamber, a two-stage gas producer turbine, and a two-stage power turbine which supplies the output power of the engine. The engine is coupled to the transmission through a freewheeling unit and main driveshaft.

Air is supplied to the engine through intakes on each side of the transmission particle separator / sand –filter, which is installed to protect the engine from the sand ingress into the engine.

The power turbine and gas producer tachometer generators are mounted on the front of the engine on the left and right sides respectively. The starter / generator is located on the right side. A turbine outlet temperature harness relays temperature measurements to an indicator on the instrument panel. An ENG OUT warning light on the caution panel illuminates when the gas producer tachometer RPM falls below a preset level.

The anti-icing system directs hot compressor discharge air over the compressor inlet guide vanes and front bearing support hub. The system is controlled by the ENGINE DEICING switch on the pedestal.

The compressor wash system directs a spray of water toward the center of the engine bellmouth. The spray fitting is mounted on the particle separator and the tubing is routed to the left side of the helicopter for easy access to an outside water source.

An hourmeter mounted in the battery compartment operates in conjunction with the engine RPM sensor. It gives an accumulative total of engine running time.

A start counter mounted on the engine records total starts, counting one start each time ignition system is energized.

FUEL SYSTEM

The fuel system consists of a single bladder type fuel cell located in the aft passenger seat bench with a capacity of 91 gallons (344 liters). The cell has been reinforced to withstand a 50 foot drop test.

ROTOR SYSTEMS

MAIN ROTOR

The main rotor is a two-bladed, semirigid system. The blades are composed of aluminum alloy parts. The hub is an underslung feathering-axis type, with six bearings that require grease. It consists primarily of a yoke fitted onto a splined trunnion and secured with pillow blocks; a pitch horn and grip assembly attached to each arm of the yoke with a tension / torsion strap; and a blade-latch mechanism located between the upper and lower tangs of each grip assembly.

TAIL ROTOR

The tail rotor is a two-bladed, semirigid rotor system mounted on the left side of the tail-boom. The all-metal blades incorporate spherical pitch change bearings. Rotor flapping is allowed by a delta hinge for stability during hovering turns and forward flight.

DUAL TACHOMETER

The dual tachometer indicates percentage of main rotor RPM (N_r) on the inner scale and power turbine RPM (N_2) of engine on the outer scale.

ROTOR LOW RPM CAUTION LIGHT

The ROTOR LOW RPM caution light will illuminate if rotor RPM drops below approximately 90%.

RPM AUDIO WARNING

An audio warning signal will sound in the pilot and co-pilot headsets when main rotor RPM decreases below 90% (simultaneous with LOW ROTOR RPM caution light illumination).

ELECTRICAL SYSTEM

The electrical system is a 28 volt direct current, negative ground system. Power is supplied by a 30 volt, 150 ampere starter – generator (derated to 105 amperes) and by a 24 volt, 13 ampere-hour nickel-cadmium battery located in the nose compartment. The starter- generator serves a dual purpose as starter and main generator. A GEN FAIL caution light (if installed) advises pilot of a failed generator.

The engine may be started from battery power or by connecting an external 28 V DC power source to the power receptacle in the nose.

The ignition system consists of a single ignitor plug and an ignition exciter box. The engine starter switch is located on the pilot's collective stick.

The battery temperature is monitored by thermal switches mounted under the battery case. The BATTERY TEMP caution light (amber) illuminates when the battery temperature is above normal and the BATTERY HOT warning light (red) illuminates when battery temperature is excessively high.

The instrument panel has integral white lights supplied by 5 Vdc power. All other lighting is 28 Vdc white lighting.

Three position lights are installed – one on each side of horizontal stabilizer and one on end of tail-boom. A red anti-collision strobe light is located on top of tail fin.

Bell 206 helicopter VT-TBA S/N 4224 was manufactured in 1992. The Helicopter VT-TBA was initially registered under the ownership of M/s Trans Bharat Aviation and

thereafter it was registered with M/s Fast Helicharters India Pvt Ltd., Certificate of registration No. 3006/3, dated 21.06.2011 under category 'A'.

The certificate of airworthiness Number 2415 under "Normal category" sub-division "passenger" was issued by DGCA on 20.08.1999 and specified minimum operating crew as 01. The maximum authorized all up weight is 1451.50 kgs. The C of A is valid up to 07.12.2012. The Helicopter was flown with Aero Mobile Licence No. A-93/01 and is valid up till 31.12.2013. This helicopter was operated under Non scheduled operator's permit No. 10-2011 and was valid up to 18.12.2013. This Bell 206 helicopter VT-TBA has logged 4732.09 A/F Hrs as on 27.08.2012 accident date.

The Bell 206 helicopter and its Engine are being maintained as per the maintenance programme consisting of calendar period based maintenance and flying Hours/ Cycles based maintenance as per maintenance programme approved by Regional Airworthiness Office, Mumbai.

Accordingly, the last major inspection done is 600 Hrs/01 year inspection at 4727:34 A/F Hrs on 05.08.2012. Subsequently all lower inspections, after last flight inspection and pre-flight checks were carried out as and when due before the incident.

The helicopter was last weighed on 12.07.2002 at New Delhi and the weight schedule was prepared and duly approved by DAW, New Delhi. As per the approved weight schedule the Empty weight is 880.7 kgs. Maximum fuel capacity is 280.20 kgs. Maximum permissible load with 01 pilot, fuel and Oil tank full is 1151.50 kgs. Empty weight CG is 292.17 Cms aft of reference in land configuration.

All the relevant Airworthiness Directive, Service Bulletins, DGCA Mandatory Modifications applicable to this helicopter and its engine have been complied with, as and when due.

The last fuel microbiological test was done on 01.08.2012 by DGCA approved facility and the colony count was within acceptable limits.

The Bell 206 helicopter is fitted with Rolls Royce Allison 250-C20J engine manufactured by Rolls Royce, Indianapolis USA. VT-TBA was fitted with Engine S/N CAE-270591 and had logged with 4571:08 Engine Hrs, 4142 cycles.

The Bell 206 helicopter VT-TBA is fitted with 02 Main Rotor Blades having a SLL of 5000:00 Hrs. Details are as below:-

The Main Rotor Blade

S/N	PART NO.	SERIAL NO.	COMPONENT HRS
1.	206-010-200-133	A-339	1024:54
2.	206-010-200-133	A-335	1024:54

There is no special maintenances programme as applicable to Main Rotor Blades ,it is included in the aircraft maintenance programme. In addition Main Rotor Brake is installed for stopping of the Main Rotor Blades at a predetermined operation after shutting down of the engine.

The status of all Airworthiness Directives as issued by FAA / Transport Canada and mandatory modifications applicable to the Helicopter were checked and found complied. Prior to accident flight there was no pending/repetitive defect entered on the Pilot Defect Report/Technical Logbook of the helicopter. The Certificate of Release to Service (CRS) issued after previous maintenance was valid prior to the accident flight.

1.7 Meteorological information:

The weather at the time of departure from Morbi was co-ordinated by PIC with ATC, Rajkot and was reported to be fine with fair visibility. The enroute weather was fine. The weather at Godhra was co-ordinated with ATC, Vadodara and the weather was reported to be fine with fair visibility.

1.8 Aids to navigation:

Landing was carried on temporary helipad, hence no navigational aid was available.

1.9 Communications:

The landing was carried out on a Temporary helipad. There was no ATC facility available at the helipad.

1.10 Aerodrome information:

The helicopter was scheduled to land on a concrete temporary helipad marked with an 'H' in an open school playground. Since it had rained the previous day, the area around the designated helipad was soft and had puddles of water.

1.11 Flight recorders:

Neither fitted nor required as per the DGCA, Civil Aviation Requirements.

1.12 Wreckage and impact information.

The helicopter first came in contact with ground on its rear right skid 37 meters short of the helipad. Thereafter it toppled over and the main rotor cut the tail boom of the helicopter and got dislodged from its mountings. The tail rotor Tail Gear Box (TGB), main rotor head and blades separated from the helicopter after impact. The TGB was found 05 meters from the fuselage and tail boom was found 50 meters from the fuselage. The main rotor head and blades were found 15.5 meters on the other side of the fuselage. The helicopter was completely destroyed as it had sustained substantial irreparable damage.

I. Wreckage Examination

Drive System

The tailboom and attached tail rotor drive system aft of the oil cooler shaft was missing and reportedly taken by local bystanders sometime after the accident. Tail rotor drive continuity could therefore not be determined. When the oil cooler tail rotor drive

shaft was rotated by hand, corresponding rotation was observed forward through the main driveshaft to the mast, demonstrating drive continuity within the main transmission. The freewheeling unit operated freely, being driven when the #4 power turbine wheel was turned by hand and rotating freely when the main or tail rotor driveshafts were rotated by hand. The three chip detectors on the main transmission revealed no debris or chips. The mast fractured below the static stop contact pad consistent with bending overload from hub to mast contact at impact (Picture 1).



Picture 1 Mast fractured below static stops

Rotation marks on the mast were consistent with the mast rotating in the dirt after impact.

The spindle mounts that connect the transmission case to the A-frame mounts on the left and right sides were intact. The four A-frame mount legs were all securely attached to roof structure (Picture 2).

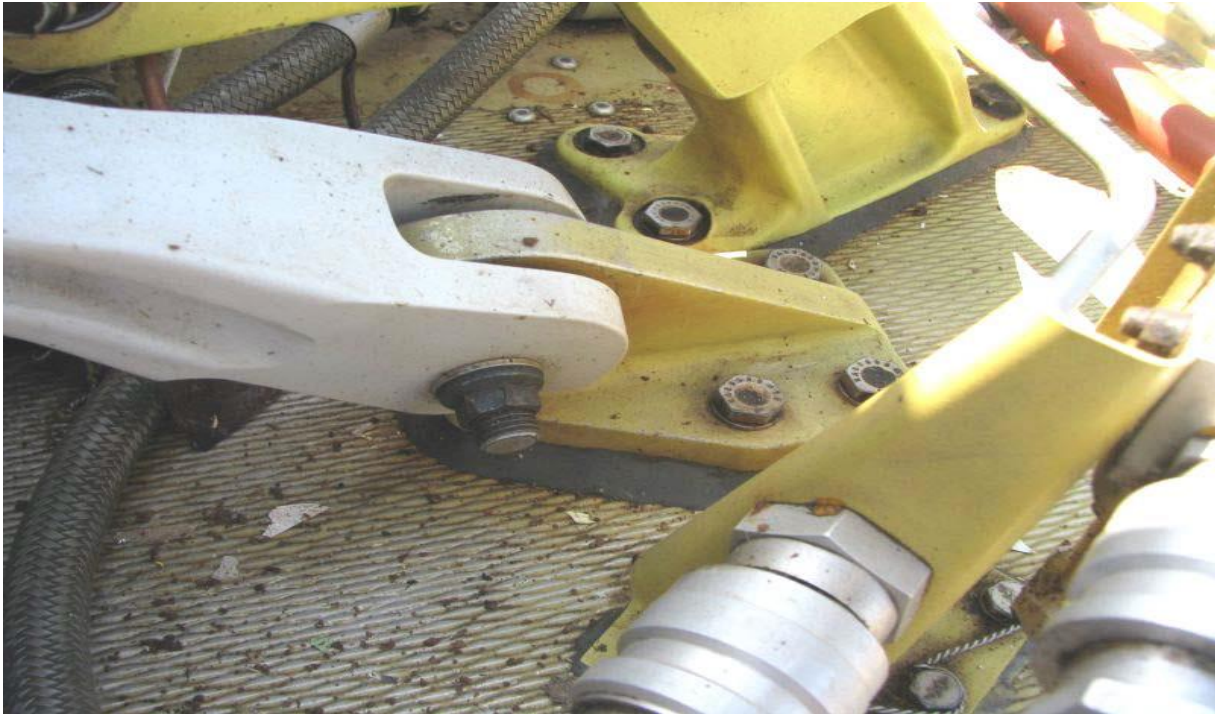

Picture 2 Right forward transmission A-frame mount solidly connected to roof structure

The main driveshaft was intact. However, overheat indicating temperature dots on forward and aft outer couplings were missing. The aft (engine side) outer coupling was missing two temp dot arrays, a red and yellow array. The remaining red and yellow temp dots were all white in color, indicating that an overheat condition had not occurred on the aft coupling. The forward (transmission side) outer coupling was missing all four temp dot arrays (Picture 3).



Picture 3 Forward outer main driveshaft coupling with no temp dot arrays installed

However, the shaft was moved fore and aft easily and grease could be felt within the forward and aft couplings.

The aft flange on the forward outer coupling made rotating contact with the isolation mount below it and aluminium material from the mount was abraded away, consistent with occurring during impact (Picture 4).



Picture 4 Isolation mount with abraded away material from rotating contact with outer coupling

The spike plate rivets had sheared indicating contact with drag pin / spike during impact

No pre-impact anomalies were observed in the examined components from the main or tail rotor drive systems and all fractures observed were consistent with overload.

Fuselage Airframe

The helicopter exhibited damage to the nose section consistent with impact loads applied when the helicopter nosed over.

The pitot tube at the front of the nose section was fractured consistent with overload forces.

The tail boom reportedly fractured at impact after being impacted by the main rotor and was at the accident site but was missing and not available for examination during the wreckage examination in Vadodara. Fractures of forward tail boom surfaces that were still attached to the aft fuselage were consistent with overload forces from a main rotor strike.

Much of the landing gear was also missing after recovery of the wreckage (Picture 5).



Picture 5 Remnants of landing gear

On the remaining landing gear available for examination, the left skid toe was observed to have fractured consistent with the nose low impact forces. All seat belts and shoulders harnesses were intact for the five seat locations and all shoulders harness inertial reels were found to operate properly by locking when pulled by hand and then releasing when pressure was relaxed.

There were no pre-impact anomalies in the fuselage airframe and all observed fractures were consistent with overload forces.

Fuel system

A small amount of clear liquid was observed in the bottom of the fuel tank through the fuel filler and vapors smelled like fuel. The aft boost pump was observed intact with the bottom end of the fuel feed line attached (Picture 6).



***Picture 6 View through fuel filler of aft boost pump and intact fuel feed line attachment
The top end of the fuel tank feed line was firmly attached to the fitting at the top of
the tank.***

Fuel lines to the fuel shut-off valve and fuel pressure transducer all appeared intact with no leakage noted (Picture 7).



Picture 7 Fuel lines to shut-off valve and fuel pressure transducer were intact

The fuel valve was removed and observed to be close (Picture 8)

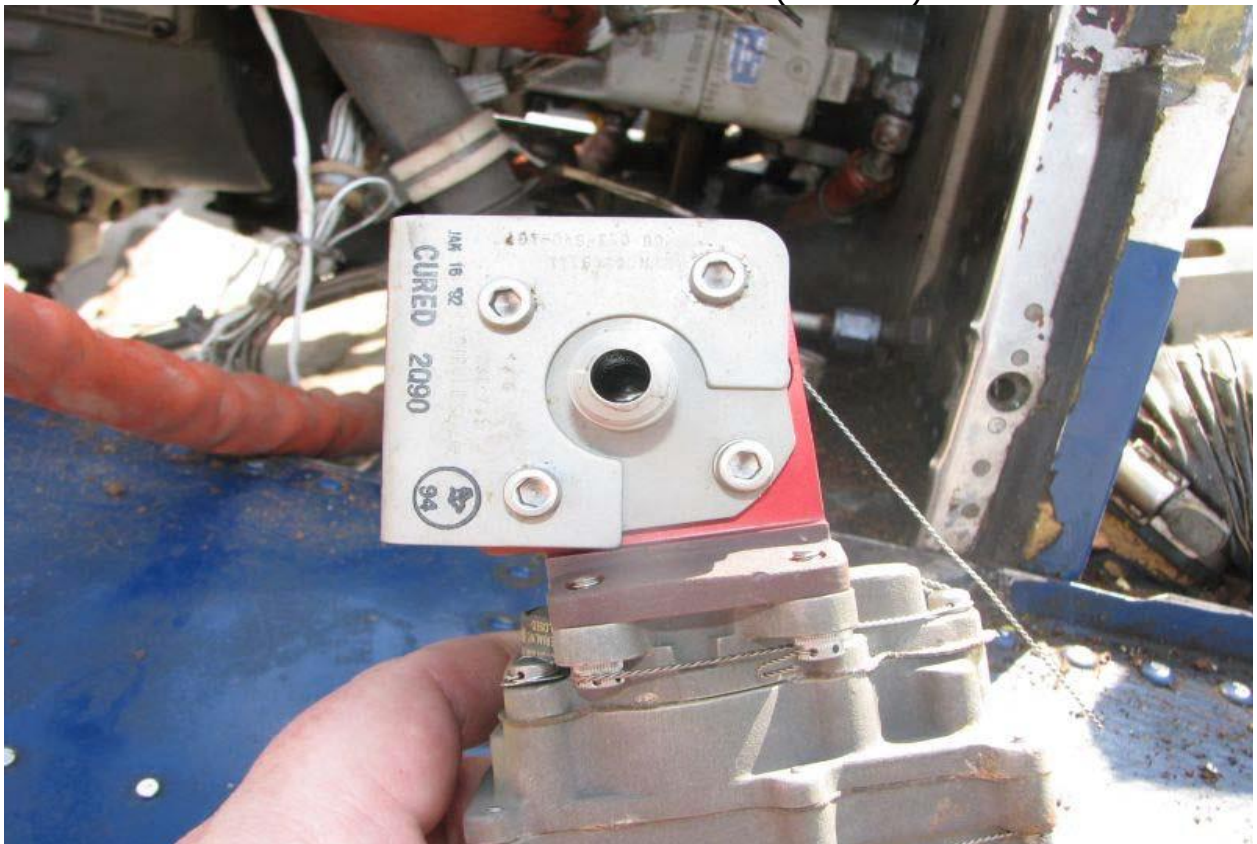

Picture 8 Fuel valve removed from mounting and observed to be in Closed position which corresponded to the Off position observed on the fuel valve switch in the cockpit (Picture 9).



Picture 9 Fuel valve switch in Off position

The pilot reported turning off switches before leaving the helicopter. Some residual fuel remained in the airframe fuel filter and the IN and OUT fuel fittings were taped off to preserve the fuel for possible future examination.

No pre-impact anomalies were observed in the fuel system.

Flight Controls

The helicopter was equipped with main rotor flight controls at the pilot position only (Picture 10).



Picture 10 Helicopter equipped with single controls at pilot station

The cyclic and collective sticks were moved by hand and corresponding control movement was observed to the servo actuators. The left cyclic servo was exercised and control movement was observed to the swash plate.

The right side servo extension tube aft of the right servo was fractured consistent with overload bending forces (Picture 11).



Picture11. Right servo extension tube fractured consistent with bending overload at impact.

The collective bell crank casting attached to the servo actuator support that receives input from the vertical tunnel control tube exhibited an overload fracture. The hydraulic reservoir sight gage exhibited fluid at the bottom of the gage. The pop-out button on the hydraulic pressure return filter was not extended, indicating that the filter was not bypassed.

The pitch change links between the swash plate and main rotor hub exhibited overload fractures consistent with departure of the main rotor at impact. The top end of both pitch change links were fractured at the clevis insert (Picture 12).



Picture 12. Top end of both pitch change links fractured at clevis inserts consistent with overload

The clevises remained attached to their respective pitch change horns. On the bottom end, one pitch change link was fractured consistent with bending overload forces approximately 6 inches from the bottom of the link (See Picture13). On the other pitch change link, the swash plate attachment ear that supports a monoball bearing was fractured (Picture 13).



Picture13 Pitch change link (red) and swash plate attachment ear (blue) overload fractures

consistent with overload forces and the link was not observed. The majority of both pitch change links were missing and not available for examination.

Since the tailboom and attached tail rotor control system were missing and not available for examination, it was not possible to fully examine the tail rotor control system. An overload fracture of the forward end of the long tail rotor control tube that transits the tailboom was observed at the aft fuselage tailboom attachment fitting (Picture 14).



Picture14 Overload fracture of long tail rotor control tube near aft fuselage tailboom attach point

This fractured tube was moved by hand and corresponding movement was observed in the tail rotor controls in the cockpit center pedestal near the tail rotor pedals. The horizontal control tube that provides continuity between the console and the tail rotor pedals exhibited fractures consistent with overload at both ends of the tube.

The pilot anti-torque pedals were intact (See Picture 15).



Picture15 Pilot anti-torque pedals intact

No pre-impact anomalies were observed in the main or tail rotor flight controls and all observed fractures were consistent with overload forces. Additionally, the pilot did not report any controls problems in-flight.

Main Rotor

The main rotor hub assembly was intact except that the pitch horn inputs to the blade grips were located on the same side consistent with impact forces, where in normal configuration the pitch horn inputs should be 180 degrees apart from one another. The mast fractured from hub to mast contact just below the static stop contact area consistent with ground impact of the main rotor blades.

Both main rotor blades had intact spars. Each plate exhibited chordwise markings at outboard surfaces consistent with striking the tail booms (Picture 16).



Picture16 Main rotor blade tip section with chordwise markings on bottom of blade

Blue paint transfers on leading edge surfaces were consistent the reported colors of the tailboom (Picture 17).



Picture 17 Blue paint transfers consistent with tailboom color on main rotor blade leading edge

One main rotor blade exhibited a downward bend approximately three feet from the tip consistent with compression forces applied at ground contact when the helicopter nose over (Picture 18).



Picture 18 Main rotor blade bent down approx. 3 feet from tip consistent with ground contact

The other main rotor blade was removed from the hub at the accident site to facilitate ground transport. The blade spar had bent forward at the approximate 2/3 span location consistent with inertial forces when the first blade made ground contact (Picture 19).



Picture19 Main rotor blade bent forward consistent with inertial forces when other blade struck round.

No pre-impact anomalies were observed on the main rotor system.

The Helicopter completely destroyed as it had sustained substantial and irreparable damage.

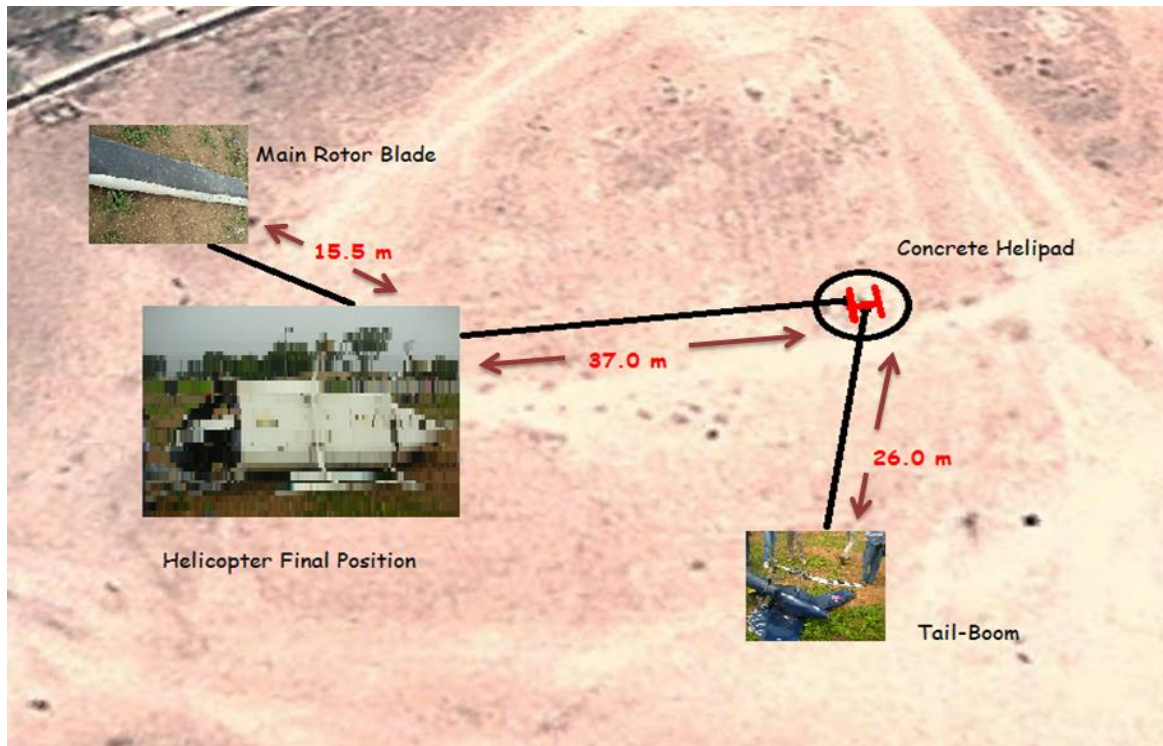

1.13 Medical and pathological Information:

Prior to flight the PIC did not undergo any pre-flight medical examination as required by CAR. Post-accident the PIC was taken to the hospital for medical examination and no injury was reported. The PIC was also clinically examined for alcohol consumption and was found satisfactory.

1.14 Fire:

There was no fire post-accident.

1.15 Survival aspects:

The accident was survivable.

1.16 Tests and research:

After the accident, preliminary investigation was carried out at the accident site and subsequently, the helicopter wreckage was transported to Vadodara, Gujarat and stored at Vadodara Airport for later examination. The manufacturer of Helicopter M/S Bell

Helicopter USA and M/S Rolls Royce-USA, the manufacturer of the Engine, associated in the inquiry.

The Engine along with fuel control unit (FCU) and power turbine governor (PTG) were sent to the manufacturer for test run and examination of Engine and components.

Video recording, obtained from the news channel, of the last phase of the flight was forwarded to Bell Helicopters for acoustic analysis.

The relevant portion of the reports submitted by the investigators from Bell Helicopter, Rolls Royce and Bell helicopter Acoustic lab are incorporated in arriving at conclusion and finalising the report.

The committee members along with the Representatives from Bell Helicopters and Rolls Royce Engines visited Vadodara for the inspection of wreckage for investigation.

The extracts from the Roll-Royce (Indiana polis-USA) report are as below :-

Physical Examination of the Engine:

The physical Examination of the Engine was carried out and the following observations were made:

Engine Information

Engine Model	:	Allison 250-C20J
Rating	:	420 SHP
Serial Number	:	CAE-270591
Engine Total Hours	:	4571.08 Hours
Engine Last Overhaul	:	1239.55 Hours



Physical Condition of the Engine

1. Control continuity was established from the collective twist grip to the engine Controls (including PTG controls) were cycled fully from stop to stop, with no unusual resistance or excessive travel noted during the control movements.
2. All engine B-nuts and fittings were checked by hand for proper torque and were found to be satisfactory.



Conditions of B-nuts

3. Several pneumatic lines were found to be secured with metal-to-metal mounting hardware, and there was no evidence of any pneumatic tubing being breached.
4. Both the N₁ and N₂ Tach-Generator's wiring was found separated from the Tach-Generator. The evidence suggests the wiring was pulled from the Tach-Generator during the accident sequence. The wires exhibited "broom-straw" breakage, which is consistent with failure in overload.
5. The engine mounts were intact with no apparent deformity. The engine exhibited no evidence of having been damaged during the crash sequence.
6. During the accident sequence, the engine-to-transmission drive coupling contacted the striker plate below it. The coupling remained intact, but left rotational witness marks that penetrated the striker plate.
7. The airframe mounted fuel filter was equipped with a filter bypass and associated "pop-up" bypass indicator. The bypass had not been activated.



Fuel-Filter 'Pop-Up' Bypass Indicator

8. Both N₁ and N₂ rotors could be rotated by hand. Rotation was smooth and quiet. Continuity from the power turbine to the power output shaft and tail rotor output shaft was established.

9. The bleed valve was checked by hand for proper operation. The valve operated smoothly with no lateral play of the poppet valve. Corrosion was noted on the outer edge of the bleed poppet.
10. The airframe fuel bladder was opened to facilitate the examination of the fuel system. A small amount of liquid, which smelled of Jet Fuel, remained in the fuel bladder.
11. The fuel cut-off valve was found in the closed position. The fuel cut-off control in the cockpit was found in the OFF position. The PIC reportedly pulled the fuel cut-off prior to exiting the aircraft. The cut-off valves was cycled and functioned normally. When positioned to the OPEN position, the valve was examined by boroscope and found to have fully opened.
12. Both the upper and lower Magnetic Chip Detectors (MCDs) were left in-place for later examination.
13. The N_1 and N_2 Tach-Generators were removed and a speed handle inserted into the respective drive gears. Both the N_1 and N_2 rotated freely by hand. 50 PSI air was applied to the Pc pneumatic line in order to check the pneumatic system for leaks.
14. A soap solution was applied to all fittings and connections and lines. No leakage was detected. The upper and lower MCDs were removed and examined. Both were found to be free of ferrous debris.

Test Run of Engine at the manufacturers facility in Indianapolis (USA)

The engine was installed on test cell #145 and a 6-point performance test was conducted to new engine production standards, in accordance with EDR 19034D. The engine successfully started, ran and shut down. The engine successfully completed ground-idle, flight-idle, max-continuous-power and take-off power runs, in addition to "wave-off" max-power increases. When corrected for standard atmospheric conditions, the engine yielded performance 11.3% below new-production standards at „low cruise“ (300 horsepower), -9.5% below new-production standards at normal cruise (370 horsepower), and +0.5% above new-production standards at maximum (Take-Off) power (420 horsepower). The engine then completed "wave-off" max-power transients,

simulating the accident sequence, where the power was reduced to flight idle and then rapidly increased to take-off power. The engine responded normally and responded with maximum power without surging or hesitation.



Engine Test Run carried out on the Test Bed

Following the successful test cell run, the compressor case halves were opened and examined. No abnormal wear, erosion or foreign object damage was noted on any internal compressor components. Evidence of corrosion was present on all compressor blades.

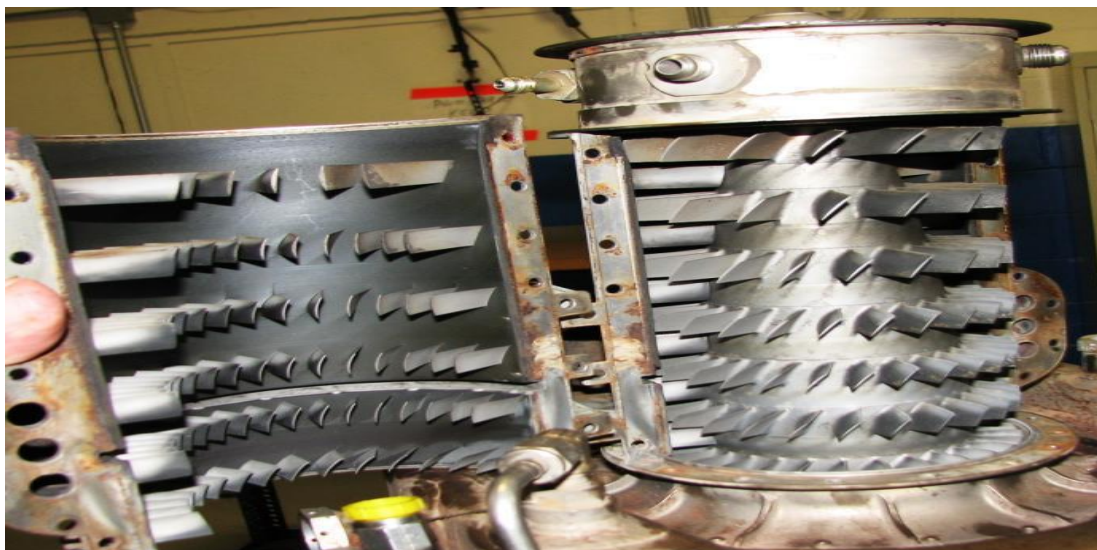

Condition of Engine's Compressor Blades

Test for Power Turbine Governor (PTG) and Fuel Control Unit (FCU) at the manufactures facility Honeywell (USA)

The engine controls (Fuel Control Unit (FCU) and Power Turbine Governor (PTG)) were removed, and sent to their manufacturer (Honeywell, South Bend, Indiana), for Test and Investigation.

Power Turbine Governor (PTG)



Power Turbine Governor

Physical Condition:

- The unit had dirt on the exterior.
- The drive shaft was free and moves normally.
- The power lever could be moved with slightly more effort than normal.
- All pneumatic ports were clear of debris.

FUNCTIONAL TESTING:

- The unit was tested using test specification TS11630 "Service Limits".
- Test point 3.010 was recorded as 4485 RPM. The test point limits are 4500 to 4570 RPM. The recorded value is not considered significantly low.

- All other test points were within limits.

CONCLUSIONS

Functional testing of the unit did not disclose any condition that would cause a sudden change in output to the fuel control. The Power Turbine Governor functioned normally.

Fuel Control Unit (FCU)



Fuel Control Unit

Physical Condition:

- The unit had dirt on the exterior.
- The drive shaft was free and moves normally.
- The power lever could be moved with slightly more effort than normal.
- All pneumatic ports were clear of debris.

FUNCTIONAL TESTING

- The unit was tested using test specification 12862 "Service Limits".
- Test point 3.010 was recorded as 2.5 Pc-Py inches of Hg. The test limits are 0.00 to 0.70 inches of Hg. This test point is affected by allowable field adjustments. This is the start de-rich adjustment that operates during the start sequence only.

- Test point 5.010 was recorded as 22.6 PPH. The test limits are 24.0 to 28.0 PPH.
- Test point 6.050 was recorded as 208.2 PPH. The test limits are 210.0 to 231.0 PPH
- Test point 6.060 was recorded as 247.8 PPH. The test limits are 252.5 to 274.5 PPH.
- Test point 7.020 was recorded as 251.5 PPH. The test limits are 279 to 286 PPH.
- Test point 9.010 could not be achieved due to the allowable field adjustment.
- All other test points were within limits.

Test Result

Functional testing of the unit did not disclose any condition that would cause a sudden change in fuel flow.

1.17 Organizational and management information:

M/s Fast Helicharters India Pvt. Ltd. is owned by 03 Directors, who run their own individual businesses apart from the company M/s Fast Helicharters Ltd. PIC involved in the accident was one of the Directors and also the Accountable Manager of the company. M/s Fast Helicharters had come into existence in June, 2011 and had a valid Non-Scheduled Operators Permit issued by DGCA. The company is engaged in day-to-day Charter Business. The company owned only one Bell 206 B III Helicopter, VT-TBA.

1.18 Additional information:

1.18.1 Video Analysis:

Since the accident flight was a chartered flight with an important public figure, there was vast media coverage for the arrival of the helicopter. After the accident, the TV channels were approached and the certified video recording was obtained for analysis. In the video recording during the approach, it is seen that the helicopter approached with high rate of descent, lowering of its nose (pitch down), and an increase in the coning of the main rotor blades is observed. Thereafter a yaw with a bank to the right is seen just prior to impacting the ground and toppling over.

1.18.2 Acoustic Analysis by Bell Helicopter - USA .

During Investigation, the higher fidelity recordings from television news camera were provided to the Representatives of the Bell Helicopters to carry out the acoustical analysis of the audio recording.

The aircraft VT-TBA was powered by a Rolls Royce 250-C20J turbine engine, and had a maximum design gross weight of 3200 lb (1451.5 kg). Characteristic frequencies of the aircraft were identified through spectrogram analysis of the audio recordings, and detailed plots of rpm time history for both rotor and engine components were plotted.

The video showing the forward starboard side of the aircraft, covers the final 30 seconds of flight before impact and 76 seconds after impact. The audio data extracted again provides information on main and tail rotor harmonics, but also provides information on a gear mesh frequency related to the compressor/gas turbine rpm (N1) before the crash. In addition, the N1- related gear mesh and the power-turbine torque meter gear rpm were identified for the full 76 seconds of audio available after impact.

It should be noted that the Bell 206B3 implements a low-rotor-rpm audio alert which activates when the main rotor rpm decreases to $90\% \pm 3\%$ (Reference 2). This audio alert consists of a steady tone. The tone would be heard inside the cockpit, but would not be audible in any of the available external camera recordings. According to Bell Flight Safety, the PIC had indicated that he heard the low-rotor-rpm alert during the descent.

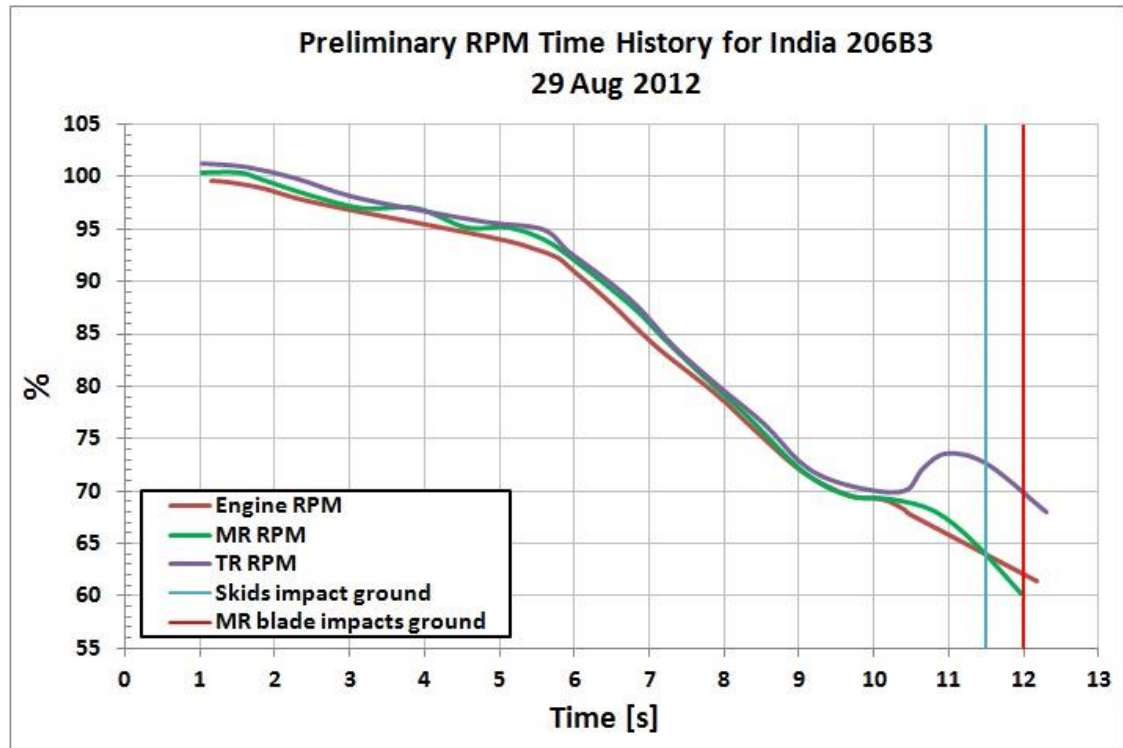

Audio Spectrogram Analysis

The audio data from recordings was analysed for frequency content and audio spectrograms were generated. Various frequency ranges and analysis parameters were used to identify several of the characteristic frequencies of the Bell 206 B III including both, the main and tail rotors and their harmonics, engine gearbox gear-mesh frequencies, and gas generator/compressor speed.

During audio spectrogram analysis the main and tail rotor frequencies and their harmonics are clearly seen and are identified. The engine gearbox torquemeter gear mesh frequency, which has a baseline (100%) value of 6000 Hz, is clearly identified.

Analysis of the video shows very similar trends for the main and tail rotor harmonics prior to the crash, and also supplies some additional information. Audio spectrograms of the recording presents the first 40 seconds of this data in the lower frequency range (0 – 600 Hz). The main and tail rotor harmonics are clearly visible before impact. A 5% increase in frequency of these harmonics is seen early in the recording and can be attributed to Doppler shift as the aircraft turns and flies toward the

camera. Given the geometry and camera location, this frequency shift indicates a ground speed of 20 – 30 kt at approximately 18 seconds before the crash. Following the crash, a tone corresponding to the engine gearbox torquemeter rotational frequency is visible through the end of the recording.

The spectrogram of the video recordings for higher frequency range (7000 – 15000 Hz) indicates a prominent compressor tone, which is coupled to N1, is visible throughout the recording. Thereafter, complete recording shows a spectrogram at a lower frequency range (0 – 240 Hz). The torquemeter tone, whose baseline (100%) value is 167 Hz, is clearly visible.

Analysis Results

The combined trends of the tones identified in the above spectrograms were transcribed in plots, the time axis corresponds to the elapsed time of the video. The plot shows the trends for NR, N2 and N1, as a percent of their nominal values, during the first 36 seconds and thereafter shows the remaining time and includes trends for N2 and N1 only, again as a percent of their nominal values.

Skid impact occurs at the video time of 29 seconds. Prior to that, the NR and N2 are at approximately 100% until about 19 seconds of video time. Then, starting at 19 seconds (10 seconds before impact) both NR and N2 decrease rapidly. The level of background noise in the audio is too high to determine NR in the final 2 seconds of flight, so NR is only shown until 27 seconds. However, it is apparent that NR reaches between 65 – 70% before impact. At ground impact, the video shows that the aircraft touches down on the right skid gear first and rolls to the left. The main rotor then strikes the tail boom, cutting off the tail rotor and vertical fin. The forward section of the tail boom, including the horizontal stabilizer, breaks off as a separate piece. The main rotor, including hub and mast, also detaches from the fuselage.

The plot further indicates that approximately 4 seconds before impact, when NR has dropped to around 80%, N1 is seen to increase sharply, reaching nearly 100% rpm at the time of ground impact. This steep rise in N1 is consistent with the PIC's increasing the throttle prior to impact. After impact N1 quickly falls to around 66%, which closely corresponds to the compressor nominal ground idle speed of 65%. The increase in N1 is followed by a brief increase in N2, which then also falls after the crash to around 63%. The pilot also indicates that the engine continued to run for approximately 65 seconds following the impact, after which the engine shuts down. During this time following the crash, N1 stays between approximately 65 – 68%, which corresponds to a power output of between 20 – 30 shp. A similar trend is seen from N2 which stays at approximately 61 – 63% during this time. At around 94 seconds both N2 and N1 begin to drop. The engine can be heard in the audio to spin down at this time.

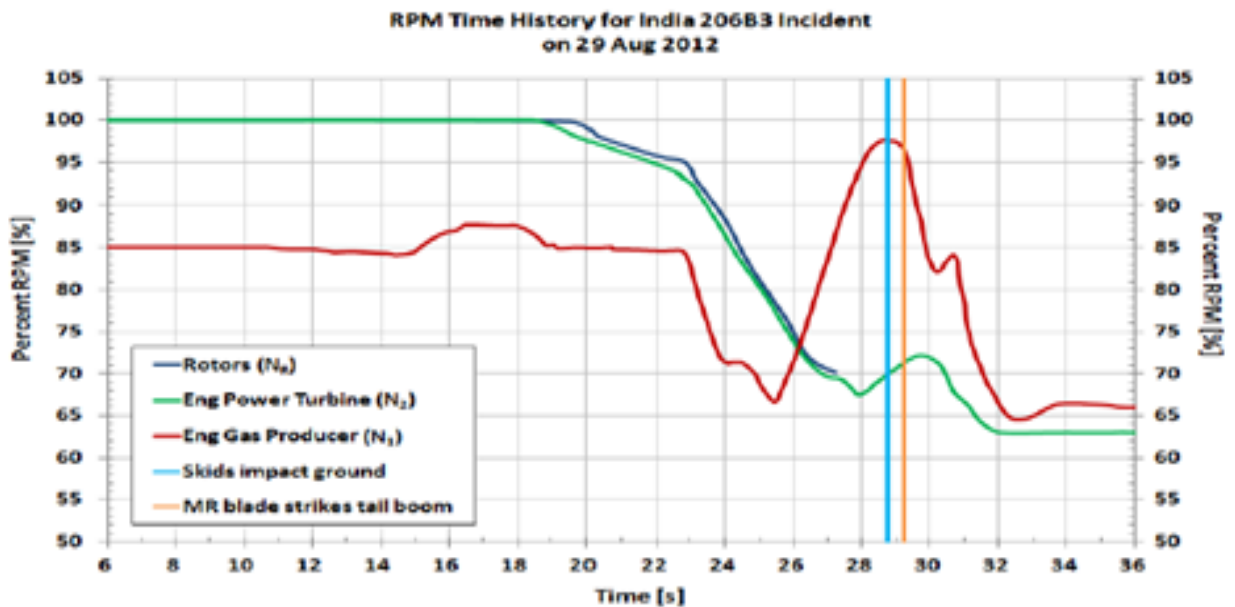

Test Result

It was concluded that during the final 10 seconds of flight, the rotor and engine power turbine speeds dropped quickly from 100% to approximately 68% at the time of ground impact. The Bell 206B3 low-rotor-rpm alert is reported to have been heard by the PIC during descent. A sharp rise in N₁ 3-4 seconds before skid impact is consistent with a

manual throttle increase. After ground impact, the engine compressor returned to ground idle speed and appeared to keep running for another 76 seconds before shutting down. Detailed plots are provided showing N_R , N_2 and N_1 time histories for the available recorded audio data.

1.18.3 Weight & Balance Calculations:

As per the Load & Trim sheet preparation by Pilot – in-Command, the AUW of the helicopter with 01 pilot & 02 passengers was 1441 kgs. However with 03 passengers the AUW of the helicopter was 1517 kgs approximately. At the time of take-off the helicopter was overloaded by approximately 66 kgs and exceeded the maximum internal take-off weight.

The helicopter operated flight for 01 hour 45 minutes burning 157 kgs of fuel approximately and the landing weight was calculated as 1360 kgs approximately and was within the limits.

1.19 Useful or effective investigation techniques: NIL

2. ANALYSIS

2.1 Serviceability of the Helicopter:

Bell 206 B III helicopter VT-TBA was manufactured in 1992. The Helicopter VT-TBA was registered under the ownership of M/s Fast Helicharters India Pvt Ltd., dated 21.06.2011 under category 'A'.

Prior to the accident, the certificate of airworthiness was current and valid up to 07.12.2012. The maximum authorized all up weight is 1451.50 kgs with 01 crew member. The Helicopter had a valid Aero Mobile Licence and was valid up till 31.12.2013. This helicopter was operated under Non-scheduled operator's permit and was valid up to 18.12.2013.

This Bell 206 helicopter VT-TBA has logged 4732.09 A/F Hrs, prior to the accident. The Bell 206 helicopter and its Engine was being maintained as per the maintenance program consisting of calendar period based maintenance and flying Hours/ Cycles based maintenance as per maintenance program approved by Regional Airworthiness office, Mumbai.

Prior to the accident, all major inspections were carried out as per the approved maintenance programme. Subsequently all lower inspections, after last flight inspection and pre-flight checks were carried out as and when due before the accident.

All the concerned Airworthiness Directive, Service Bulletins, DGCA Mandatory Modifications on this helicopter and its engine have been complied with as & when due.

The status of all Airworthiness Directives as issued by DGCA through mandatory modifications for Helicopter including Main Rotor blades were also checked and found satisfactory.

Prior to accident flight there was no pending/repetitive defect entered on the Pilot Defect Report/Technical Logbook of the helicopter. The Certificate Release to Service was valid prior to the accident flight. Examination of the wreckage site also revealed that there was no in-flight disintegration of the helicopter parts. The parts had disintegrated only after the impact with the ground.

In view of the above, it is inferred that the serviceability of the helicopter is not a factor to the accident.

2.2 Weather:

Since, the helipad at Morbi and Godhra were temporary helipad, no MET services were available. The weather at the time of departure from Morbi was co-ordinated by PIC with ATC, Rajkot and was reported to be fine with fair visibility. The enroute weather was fine. The weather at Godhra was co-ordinated with ATC, Vadodara and the weather was reported to be fine with fair visibility.

2.3 Pilot handling of the helicopter:

The helicopter VT-TBA had arrived at Morbi helipad on 27.08.2012 and was scheduled for a flight on 29.08.2012. The helicopter departed from Morbi to Godhra at around 0800 UTC. The flight was planned with 03 passengers, however, 04 passengers boarded at Morbi for the flight. A load and trim sheet based on the planned flight had been prepared catering for 01 pilot, 03 passengers with 75 (284 ltrs) gallons of fuel. As per the calculations at the time of take-off the helicopter was overloaded by approximately 66 kgs and exceeded the maximum internal take-off weight. However the helicopter operated flight for 01 hour 45 minutes, burning 157 kgs of fuel approximately and the landing weight was calculated as 1360 kgs approximately, which was within the limits. The helicopter though being overloaded for the flight from Morbi, the PIC initiated the flight without assessing the effect on performance of the helicopter with an additional passenger. The flight from Morbi to Godhra was uneventful.

On reaching overhead Godhra, the PIC made a large circle to identify the landing site, assess the helipad (concrete), obstructions around the helipad, winds and being satisfied, decided upon the approach direction before commencing the descent.

In the video recording, during the approach, the helicopter rate of descent is seen to increase following by lowering of its nose (pitch down), an increase in coning of the rotor blades and a yaw with a bank to the right just prior to impacting the ground and toppling over. It is observed that helicopter crossed the high-tension cables with sufficient clearance, thereafter, the helicopter appeared to experience a sink and subsequent pitch down. In the final stages, before touch-down, the helicopter is seen yawing and banking to the right and the right rear skid contacting the ground, followed by it toppling over.

The PIC after crossing the high-tension wires with sufficient clearance, continued the approach. After crossing the obstruction, the PIC experienced a sink which he realized that the approach was undershooting and that the helicopter would arrive short of the helipad. Though the PIC mentioned that the Main Rotor and engine indicator

showing 97% rpm, the helicopter experienced a sink after crossing the wires. To arrest the sink, he came up on collective and noticed that the main rotor and engine rpm indicator decreased and stabilized between 97% and 90 % and the approach becoming undershooting which he deliberately did not correct. Subsequently he lowered the collective to regain the rpm. The PIC assessing the situation to be one of a governor failure (engine under speeding), he decided to carry out a no hover landing with forward speed. At this point the main rotor/engine rpm had not reached the minimum limit of 90 %, at which the low rotor rpm audio warning would have sounded.

Close to the ground approximately 25 feet AGL, the PIC started applying the collective to arrest the rate of descent and to reduce the forward speed. On application of collective, the rotor rpm dropped below 90 % and the low rotor rpm audio warning horn sounded. On hearing this, the PIC rapidly applied full collective and the throttle opened to almost full on as evident from the acoustic analysis, that 3 to 4 seconds prior to impact, the throttle was manually increased to full power. Although N_1 increased significantly in 3 to 4 seconds prior to impact from an apparent increase in throttle to full on, there was not enough time for N_2 and N_R recovery prior to impact. This action caused the helicopter to yaw and bank to the right which he did not correct/control and the helicopter impacted the ground on the right rear skid while still moving forward. Subsequently the left skid contacted the ground and dug in to the soft ground arresting its forward speed but its forward momentum caused the helicopter to topple over.

Even though the PIC had wrongly assumed/identified the decrease in the main rotor/engine rpm as a case of governor failure (engine under speeding), he should have executed an autorotative landing with the power available and with positive zero forward speed.

During investigation, the engines along with its components (Fuel Control Unit, Power Turbine Governor) were strip examined / test run and were found satisfactory. As per the report, all the components and engine were serviceable prior to the accident.

From the foregoing, it is evident that the handling of the Flight/Engine Controls by the PIC is a primary factor to the accident.

2.4 Circumstances leading to the accident:

The flight from Morbi to Godhra was planned for 03 passengers, however 04 passengers boarded the helicopter from Morbi. The PIC initiated the flight without assessing the effect on performance of the helicopter with an additional passenger. The flight from Morbi to Godhra was uneventful. Prior to the accident flight, the flight was planned with 03 passengers, however, it took off with 04 passenger. The helicopter was overloaded prior to its departure from Morbi. After flying for 1 hour 45 minutes, the helicopter was within the landing weight limits.

In the reconnaissance of the area around the helipad at Godhra, the PIC did not notice puddles of water at many places around the designated concrete helipad. As it had rained the previous day, the ground was soft.

After crossing the high-tension wires, the helicopter experienced a sink and subsequently he lowered the collective to regain the rpm. To arrest the sink, he came up on collective and noticed that the main rotor and engine rpm had decreased. This was probably due to a variation in the throttle position as evident from the acoustic analysis.

The PIC realized that the approach was undershooting and that the helicopter would arrive short of the helipad. Landing on such ground should have been avoided, especially with forward speed, as it could result in the helicopter skids getting bogged down in the soft ground and cause the helicopter to nose over. Landing on such soft ground should have been with 'zero' forward speed, however the PIC chose to land with forward speed.

At approximately 25 feet above the ground, on applying the collective and hearing the low rotor RPM audio horn, the PIC opened the throttle (evident from the acoustic analysis) and came up on full collective. Lack of coordination of controls in the final

moments of the flight, wherein the helicopter was permitted to yaw and bank to the right while touching down with forward speed resulted into the accident.

3. CONCLUSIONS:

3.1 Findings:

- a) The Certificate of Airworthiness and the Certificate of Registration of the helicopter was valid on the date of accident.
- b) The certificate release to service (CRS) was valid at the time of accident.
- c) The PIC was holding a valid license on the type of helicopter.
- d) The PIC had not undergone the simulator recurrent training as required by CAR. All the other ancillary trainings were valid.
- e) The flight from Morbi to Godhra was planned for 03 passengers, however, 04 passengers boarded the helicopter. The helicopter took – off for flight without making any corrections/changes in the Load & Trim Sheet to cater for the additional passenger for power and CG variations.
- f) During the aerial reconnaissance overhead Godhra, the PIC did not notice the puddles of water and appreciate that the area around the helipad was soft ground.
- g) After crossing the high-tension wires, the helicopter experienced a sink and the PIC realized that the approach was undershooting and that the helicopter would arrive short of the helipad.
- h) To arrest the sink, the PIC came up on collective, and observed that the main rotor and engine rpm indication had decreased. Subsequently he lowered the collective to regain the rpm.
- i) The PIC wrongly assessing the situation to be one of a governor failure, decided to carry out a no hover landing with forward speed.
- j) At approximately 25 feet AGL, the PIC applied collective to arrest the rate of descent and to reduce the forward speed. The rotor rpm dropped below 90 % and the low rotor rpm audio warning horn sounded.

- k) The PIC rapidly applied full collective and opened the throttle to almost full power. This action caused the helicopter to yaw and bank to the right which he did not correct/control and the helicopter impacted the ground.
- l) The engine, along with its components (Fuel Control Unit and Power Turbine Governor), was sent to the manufacturer's facility for strip examination and test run. All the units were found satisfactory.
- m) The weather was not a factor to the accident.

3.2 Probable cause of the Accident:

The rapid and large collective movements in the final stage with inadequate left rudder application resulted in the helicopter yawing and banking to the right. These actions eventually resulted into the accident.

Following were the contributory factor:

- The reduction in the throttle setting after crossing the wire obstruction on the approach, most probably resulted in setting off a sequence of events leading to the drop in Engine and Main Rotor RPM and causing the PIC to assess the situation as one of governor failure (Engine underspeed).
- Mishandling of the controls in the final moments of the approach, just prior to the landing.
- Incorrect procedure/technique adopted for landing on soft ground.

4. SAFETY RECOMMENDATIONS:

1. DGCA shall reiterate its instructions on the importance of the correct preparations of Load & Trim Sheets by the operating crew prior to the flights to all NSOP / Private Operators.
2. DGCA shall reiterate its instructions on the importance of the simulator training to all helicopter operators, as required by CAR Section 7, Series B Part XIV.
3. Passenger briefing was not carried out. In the absence of passenger briefing, the passenger could have been exposed to grave danger. DGCA should reiterate the instructions for the same.
4. During simulator training, the importance of carrying out landings with no residual forward speed on soft ground needs to be highlighted.

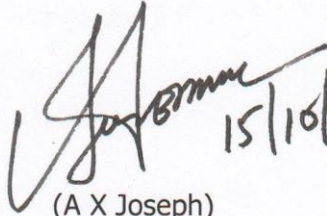

15/10/14

(A X Joseph)
Assistant Director
Member, COI VT-TBA



(Capt. J P S Kniggar)
Ops. Member, COI VT-TBA

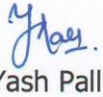

14/10/14.

(Yash Pall)
Chairman, COI VT-TBA

AAIB	Aircraft Accident Investigation Bureau,India
AGL	Above Ground Level
A/F	Airframe Hours
AOA	Angle of Attack
AMSL	Above Mean Sea Level
AME	Aircraft Maintenance Engineer
ARC	Airworthiness Review Certificate
ASB	Alert Service Bulletin
ATC	Air Traffic Control
AUW	All Up Weight
C of A	Certificate of Airworthiness
CAR	Civil Aviation Requirements
CEB	Commercial Engine Bulletin
CSL	Commercial Service Letter
CG	Centre of Gravity
CPL(H)	Commercial Pilot License (Helicopter)
CP	Collective Pitch
CRM	Crew Resource Management
CVR	Cockpit Voice Recorder
CSL	Commercial Service Letter
CT	Compressor-to-Turbine Coupling
DAW	Director of Airworthiness
DDG	Deputy Director General
DGCA	Directorate General of Civil Aviation
DGR	Dangerous Goods Regulations
DFDR	Digital Flight Data Recorder
FAA	Federal Aviation Administration
FCU	Fuel Control Unit (Engine)
FRTOL	Flight Radio Telephone Operator's License
FSN	Fuel Spray Nozzle
ISRO	Indian Space Research Organization
LH	Left Hand
L & T	Load & Trim
MCD	Magnetic Chip Detector
NDT	Non Destructive Testing
NSOP	Non-Scheduled Operating Permit
NTSB	National Transportation Safety Board, USA
N ₁	Gas Generator rpm
N _R	Rotor rpm

N ₂	Power Turbine rpm
PIC	Pilot In Command
Pax.	Passenger
PTG	Power Turbine Governor
RH	Right Hand
rpm	Revolution per minute
RT	Radio Telephony
RTR (C)	Radio Telephony Restricted
SOP	Standard Operating Procedures
SHP	Shaft Horse Power
Vdc	Volts (Direct Current)
VHF	Very High Frequency
UTC	Co-ordinated Universal Time